

**PLX**

## EF Termination Fittings



PLX Termination fittings have been specifically designed for use as an end of line connection as part our leading fuel pipework system, PLX.

The fittings enable PLX secondary contained close fit pipe to be terminated to a single wall connection all within one fitting, while maintaining secondary containment throughout the pipeline. Therefore, reducing the number of preparation steps, fittings and welding sequences required over traditional termination assemblies.



Reduces the amount of time and parts required during installation



Interstitial monitoring options



Designed for use with PLX secondary contained close fit pipe



Manual and barcode welding options



Compact design vs traditional methods



Adheres to Blue Book recommendations



# PLX EF Termination Fittings

## Interstitial Monitoring

PLX Termination Fittings are available with 1/8" BSP Female stainless steel test ports for leak detection system requirements.

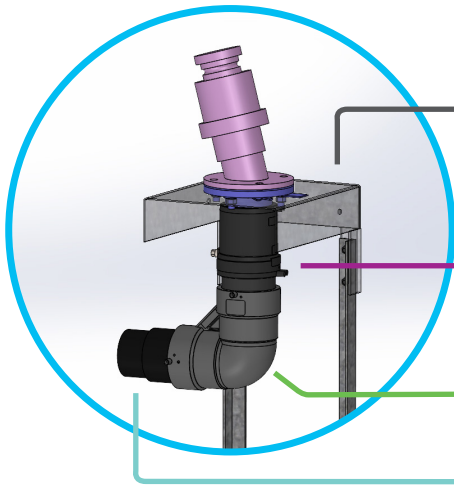
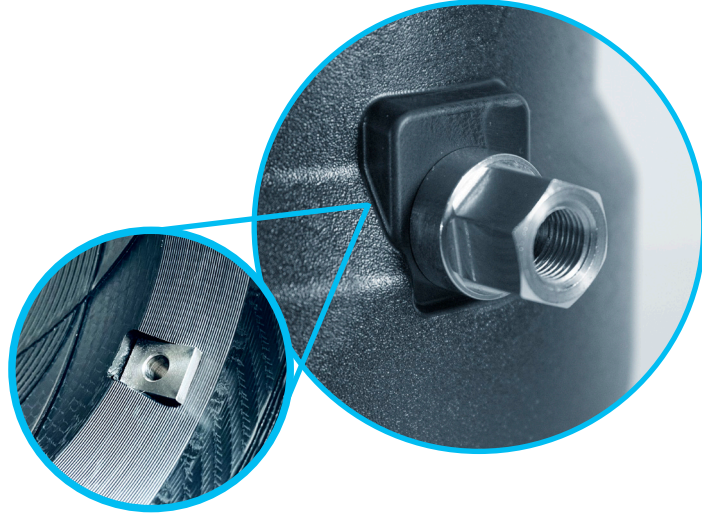

### Fill point arrangement

Off set fill frame

PLX Termination Fitting

PLX One-Weld Elbow

PLX Secondary Contained Close Fit Pipe

## PLX Hand-Held Pipe Clamp

Designed to easily secure both primary and secondary PLX pipes in position during electrofusion jointing to prevent movement.



**PLX**

# EF Termination Fittings



The PLX Termination Fittings are available in two sizes.

### 63#75 x 63mm



Designed to connect horizontally to tank chamber connections utilising our new "one-weld" electrofusion technology.

### 110#125 x 110mm



Primarily designed for vertical installation to offset fill points and encompasses a two weld electrofusion process to aid installation.

Product code	Description
43452445	PLX 63-75/63mm Termination Fitting
43452447	PLX 110-125/110mm Termination Fitting
43453445	PLX 63-75/75mm Termination Fitting Inc. Test Port
43453447	PLX 110-125/110mm Termination Fitting Inc. Test Port

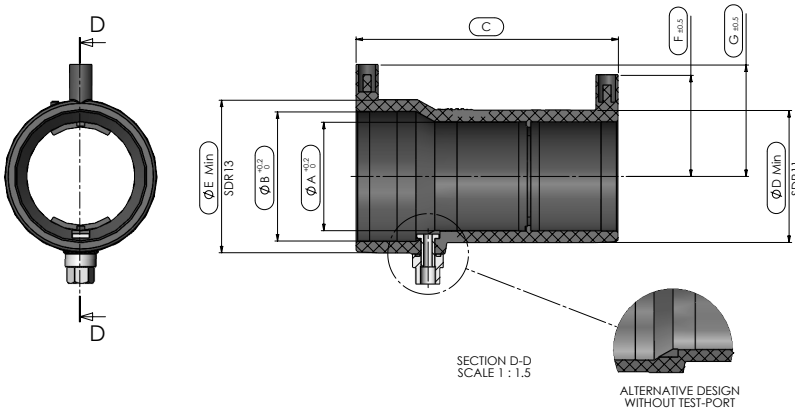

Size	A	B	C	D	E	F	G
63#75 x 63mm	63.25	75.25	153	77	89	59	65
110#125 x 110mm	110.6	125.6	165	135	148	82.9	90.4

**alixis.co.uk**

T • +44 (0) 1543 471680  
 E • enquiries@durapipe.co.uk

Aliaxis UK reserves the right to modify the details in this publication as products and specifications are updated and improved. The content of this publication is for general information only and it is user's responsibility to determine the suitability of any product for the purpose intended.

Glynwed Pipe Systems Ltd t/a Aliaxis UK, registered in England 01698059.  
 Registered Office: Dickley Lane, Lenham, Maidstone, Kent, ME17 2DE.